

Product Overview

- ❶ Low Voltage Boost Button
- ❷ Power On/Light Button
- ❸ LED Light
- ❹ EC5 Engine Start Port
- ❺ USB-A Output 2: 5V/2.4A
- ❻ USB-A Output 1: QC3.0 18W
- ❼ USB-C Input: QC3.0 18W
- ❽ 2.3" Digital Screen

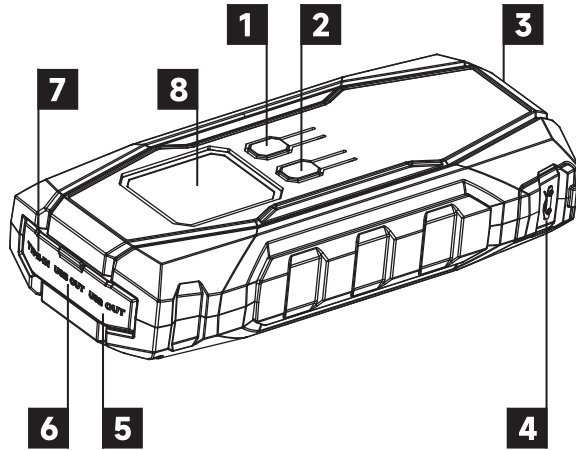

- ❾ READY Indicator
- ❿ Reverse Connection Warning Indicator
- ⓫ High Temperature Indicator
- ⓬ Low Battery Indicator
- ⓭ Recharging Indicator
- ⓮ Charging Indicator

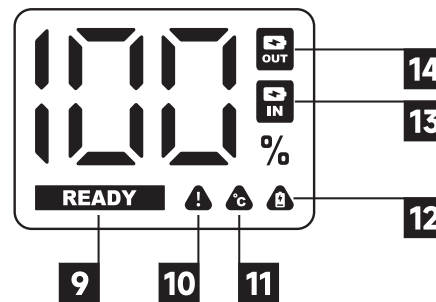

Indicator Icons

READY	READY Indicator: Green READY light indicates the vehicle is ready to start.
	Reverse Connection Warning Indicator: Icon will turn red when clamps are reversed. Please make sure red clamp is connected to (+) and black clamp to (-).
	High Temperature Indicator: Icon will turn red when the operating temperature is too high. Continue using after 10 minutes cooling period.
	Low Battery Indicator: Icon will turn red when the battery level is low. Please fully charge unit before using.
	Recharging Indicator: Icon will turn green when the jump starter begins to recharge.
	Charging Indicator: Icon will turn green when a device is connected for charging.

Button Instruction



Press the button to turn on the device.
Press for 3 seconds then press each time for Flashlight/SOS/Strobe modes.
Press for 3 seconds during light mode to turn the light off. The unit will power off automatically after 45 seconds of non-use.



Press the button for 3 seconds to activate the boost starting feature when the battery level is less than 2V.

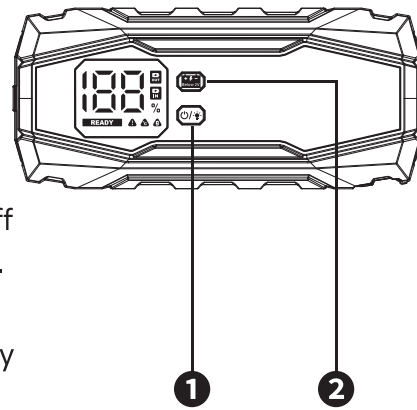

- ① Power On/Light Button ② Low Voltage Boost Button

What's In The Box

Main Unit	Black/Red Jumper Cable	USB A-C Charging Cable
User Manual	Carry Case	

Steps To Jump Start Your Vehicle

Method 1: Normal Jump Starting

1. Plug cable end into the Engine Start Port.
2. Hook up the red (+) clamp to the positive (+) terminal of the vehicle battery, the black (-) clamp to the negative (-) terminal, and ensure that the connections are secure.
3. Wait for the solid green **READY** light appears on the screen, then start

your vehicle within 40 seconds. (If the light fails to illuminate green despite the correct connection of the positive and negative terminals, please engage the boost jump starting mode.)

4. Start Engine then immediately remove the clamps from the battery terminals.

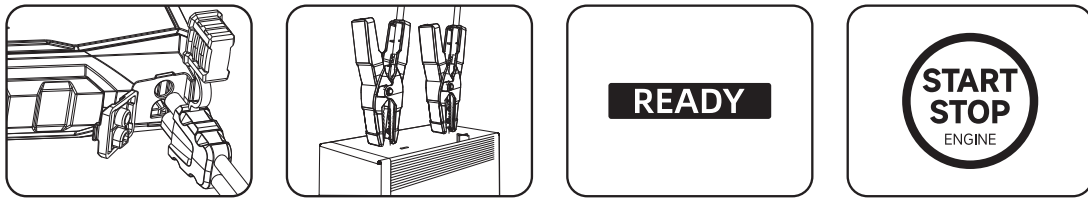

Method 2: Boost Jump Starting For Low Voltage Batteries Less Than 2V

1. Plug cable end into the Engine Start Port.
2. Hook up the red (+) clamp to the positive (+) terminal of the vehicle battery, the black (-) clamp to the negative (-) terminal, and ensure that the connections are secure.
3. If the **READY** light on the screen fails to illuminate, and the positive and negative terminals of the clamps are connected correctly, please press the boost button  on the main unit for 3 seconds until it lights up green, then start your vehicle within 30 seconds.
4. Start Engine then immediately remove the clamps from the battery terminals.

! Warning: All safety features disable when using the boost feature. Please make sure red clamp is connected to (+) and black clamp to (-).

Charge Your Devices

You can charge your phones, tablets, cameras, drones, and more using the "USB OUT" ports. The product can charge two devices simultaneously.

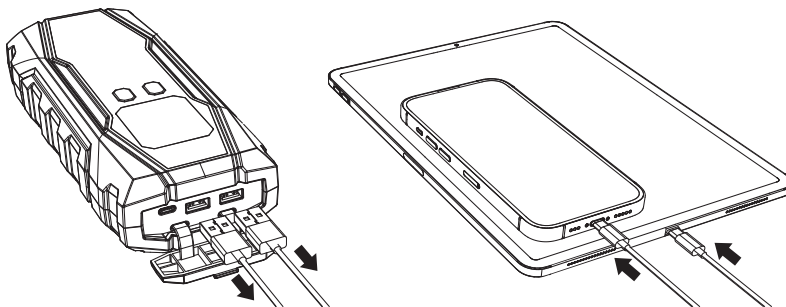

Charge T18 Jump Starter

Plug the USB-C end of the included charging cable into the "USB-C IN" Port on the jump starter, and connect the other end to a charger. We suggest purchasing a QC3.0 18W quick charger.

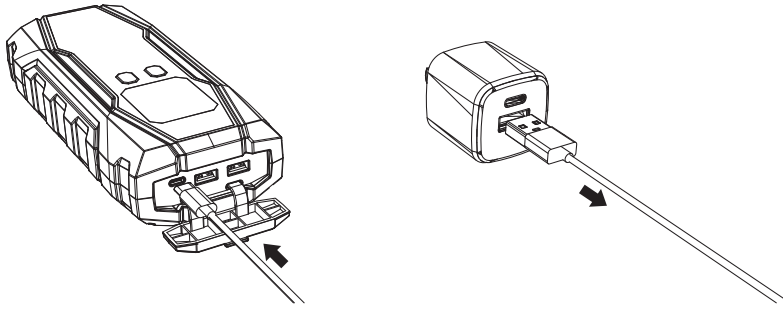

Caution

1. Do not remove the screws to open the unit. The unit does not have any serviceable components inside. The warranty will be void if the unit has been tampered with.
2. Do not discard unit into fire. The lithium battery will cause a fire and possible explosion.
3. Keep out of direct sunlight and extreme hot or cold temperatures.
4. This is not a toy. Keep safely stored away from children. Children should not be present when using the jump starter.
5. Keep unit dry. The unit should not be used near standing water or wet areas such as bathtubs, showers, sinks, swimming pools or basements.
6. It is strictly forbidden to use this product in an environment where flammable gas is present.
7. Stop using the jump starter if you notice leaks, smells, or deconfiguration of the jump starter case.
8. Charge jump starter if battery level is 10% or below before using it to avoid damage to the unit.
9. Charge unit fully before first time using.

STORAGE: -4°F ~ 158°F (-20°C ~ 70°C)

DISCHARGE: 14°F ~ 122°F (-10°C ~ 50°C)

CHARGE: 32°F ~ 113°F (0°C ~ 45°C)

CAROSS LLC

990 Industrial Rd.
San Carlos, CA 94070
Support@caross.net

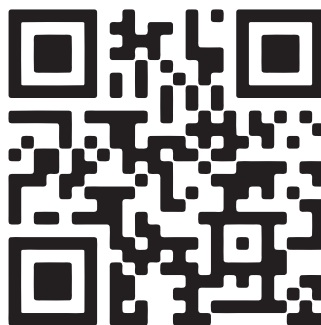

How-To Video